

# Alcohol Consumption Detector for Classroom Using IoT

Dr. V.Vinodhini<sup>1</sup>, Abinayaa. V<sup>2</sup>, Nandhini. J<sup>3</sup> and Vignesh. B<sup>4</sup>

<sup>1</sup>Professor, Department of Computer Science, Dr. N.G.P Arts and Science College, Coimbatore, INDIA

<sup>2</sup>Student, Department of Computer Science, Dr. N.G.P Arts and Science College, Coimbatore, INDIA

<sup>3</sup>Student, Department of Computer Science, Dr. N.G.P Arts and Science College, Coimbatore, INDIA

<sup>4</sup>Student, Department of Computer Science, Dr. N.G.P Arts and Science College, Coimbatore, INDIA

<sup>3</sup>Corresponding Author: 212cs017@drngpasc.ac.in

Received: 13-03-2023

Revised: 29-03-2023

Accepted: 26-04-2023

## ABSTRACT

The primary goal of the project is to develop a system that can detect the presence of alcohol in a classroom environment using an alcohol sensor and IoT technology. The system will be designed to monitor the classroom environment continuously and alert the teacher and school administration when alcohol is detected. . The system will consist of an alcohol sensor that will be placed in the classroom. This sensor will be able to detect the presence of alcohol vapors in the air. The alcohol sensor will be connected to a micro-controller, which will process the data and send it to the cloud through the internet. In the cloud, the data will be stored and analyzed. An application will be developed to display the results of the alcohol detection. The application will provide real-time information about the alcohol levels in the classroom. It will also display historical data and trends, which can help the school administration to identify patterns and take corrective actions. The system will be designed to send notifications to the teacher and school administration in case of alcohol detection. This will enable them to take appropriate actions, such as contacting parents, counseling students, or taking disciplinary actions. The notifications can be sent through email, text message, or a dedicated app. Overall, the project aims to help prevent alcohol consumption among students in schools. Alcohol consumption can have a significant impact on students' health and academic performance. By detecting alcohol in the classroom environment, the system can provide an early warning system, enabling school administration to take preventative measures and provide support to students who may be at risk.

**Keywords--** Alcohol Sensor, LCD, IOT, GPS Modem

## I. INTRODUCTION

Alcohol consumption among students in schools is a significant concern that can have adverse effects on their health and academic performance. Schools and parents need to monitor and prevent underage drinking to ensure a safe and healthy environment for students. However, detecting alcohol consumption in a classroom environment can be challenging, as it is difficult to detect alcohol using traditional methods. To address this challenge, this project

proposes the development of a system that can detect the presence of alcohol in a classroom environment using an alcohol sensor and IoT technology. The system will be designed to monitor the classroom environment continuously and alert the teacher and school administration when alcohol is detected. The proposed system will consist of an alcohol sensor that will be placed in the classroom, which will be connected to a micro-controller that will process the data and send it to the cloud through the internet. The data will be stored in the cloud, and an application will be developed to display the results of the alcohol detection. The system will send notifications to the teacher and school administration in case of alcohol detection, enabling them to take appropriate actions. The system can help prevent alcohol consumption among students in schools, which can have a significant impact on their health and academic performance. Overall, the proposed system can be a valuable tool for schools and parents to monitor and prevent alcohol consumption among students. The system can provide an early warning system, enabling school administration to take preventative measures and provide support to students who may be at risk.

## II. LITERATURE SURVEY

1. "Alcohol Detection in Classrooms using IoT", published in the International Journal of Emerging Technology and Advanced Engineering (IJETA), proposes a system that uses an alcohol sensor to detect alcohol levels in the classroom and sends notifications to the concerned authority in case of a dangerous situation.
2. "Smart Alcohol Detection System for Social Drinking Environment using IoT", published in the IEEE Sensors Journal, presents a smart alcohol detection system that uses a wearable device to monitor alcohol consumption levels and sends notifications to the user and the concerned authority.
3. "Real-time Alcohol Detection System using IoT and Machine Learning", published in the International Journal

of Computer Applications, proposes a real-time alcohol detection system that uses IoT and machine learning techniques to monitor alcohol consumption levels in the classroom and send notifications to the concerned authority.

### III. METHODOLOGY

In designing an alcohol consumption detector for a classroom using IoT methodology requires careful hardware selection, sensor calibration, data acquisition, data transmission and analysis, notification system, user interface, and power supply. The final device will be able to detect alcohol consumption levels in the classroom and alert the concerned authority in case of a dangerous situation.

### IV. WORKING PRINCIPLE

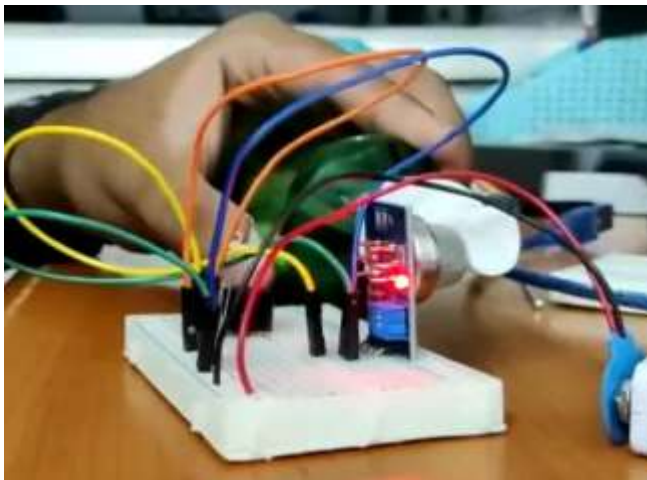

Figure 1: Working Principal of ACD

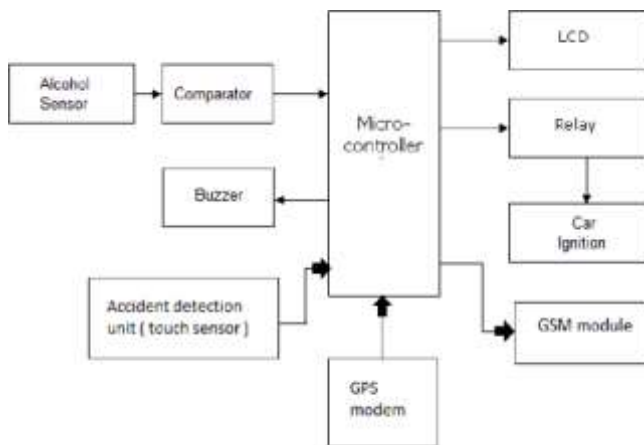

Fig 2: Architecture of ACD

### V. PROBLEM STATEMENT

The problem statement for designing an alcohol consumption detector for a classroom using IoT methodology is as follows: Alcohol consumption among students in the classroom is a serious concern for educational institutions as it can lead to a decrease in academic performance, unsafe behavior, and potential harm to oneself and others. Traditional methods of detecting alcohol consumption, such as physical observation or breathalyzer tests, are often inaccurate or intrusive. Therefore, there is a need for a non-intrusive and accurate method to detect alcohol consumption in the classroom. To address this problem, an IoT-based alcohol consumption detector can be designed that will use a calibrated sensor to measure the levels of alcohol in the classroom. This device will provide a non-intrusive way to monitor the alcohol consumption levels in the classroom, and alert the concerned authority in case of a dangerous situation. This will help educational institutions to take timely action to prevent any harm or disruption caused by alcohol consumption in the classroom.

### VI. RESULT

The alcohol consumption detector for a classroom using IoT methodology will provide real-time data on alcohol consumption levels in the classroom. This data can be used to track and monitor student behavior, and help prevent dangerous situations from occurring. If the alcohol consumption levels exceed a certain threshold, the system will trigger a notification system, alerting the concerned authority about the situation. This will allow them to take appropriate action to prevent any harm from occurring. In addition, the system can be integrated with a user interface that will display real-time data on alcohol consumption levels in the classroom. This will help teachers and administrators monitor student behavior and intervene if necessary. Overall, the alcohol consumption detector for a classroom using IoT methodology will provide a reliable and effective way to monitor alcohol consumption levels and prevent dangerous situations from occurring.

### VII. CONCLUSION

In conclusion, the Smart Parking System using IoT is an innovative solution that provides a convenient and efficient way to manage parking spaces. With the integration of IoT technologies such as sensors, wireless communication, and cloud computing, the system can monitor and manage parking spaces in real-time. The system allows drivers to easily locate available parking spaces and reserve them in advance, reducing the time spent searching for parking spots. The hardware design of

the system includes the use of sensors and micro-controllers to detect the presence of vehicles in parking spaces and transmit the data to the cloud server. The cloud server then processes the data and sends it to the mobile application, allowing users to view the availability of parking spaces and reserve them. provides a user-friendly interface for drivers to locate available parking spaces, reserve them, and pay for parking fees. The application also includes features such as real-time parking space availability updates and notifications for expired parking reservations. Overall, the Smart Parking System using IoT is a promising solution to the growing problem of parking space management. By leveraging the power of IoT technologies, the system can provide a seamless and convenient experience for drivers while optimizing the use of parking spaces. Future enhancements to the system could include the integration of artificial intelligence algorithms for predictive blockchain technology for secure and transparent parking.

## REFERENCES

- [1] Keerthana K, Ramya G. (2018). Drunk driving detection using car ignition locking. *International Journal of Pure and Applied Mathematics*.
- [2] Tejaswini Patil & Aliya Tabassum. (2018). Automatic engine locking system alcohol detection for drunk & drive with GSM. *National Conference on Advances in Engineering and Applied Science*.
- [3] Muthulakshmi.M, Santhiya.K & Prof.Dhivya.P. Smart helmet system using alcohol detection for vehicle protection. *IJIRTSE*, 2.
- [4] Prof. Kulkarni P.H, Ms. Ravina Wafgaonkar & Mr. Gaurav Ahirrao. (2019). Alcohol detection and automatic drunk and drive avoiding system. *International Journal of Engineering Research and Applications*.
- [5] M.H. Mohamad, Mohd, AminBin & Hasanuddin. Vehicle accident prevention system embedded with alcohol detector. *IJRECE*, 1(4).
- [6] Alcohol detection and accident prevention of vehicle. *IJIJERE*, 2(3).
- [7] Dr. V.Vinodhini. (2023). Privacy protection in vehicular networks based on blockchain and edge intelligence. *Journal of Survey in Fisheries Sciences*, 10(1S).
- [8] Dr. V. Vinodhini. (2021). A study on web based immunity prediction using artificial intelligence. *International Journal of Research and Analytical Reviews (IJRAR)*, 8(2).
- [9] Dr. V. Vinodhini. (2021). A study on behavioral analysis of specific ransomware and its comparison with DBSCAN- MP. *International Journal of Scientific Research in Computer Science Engineering and Information Technology (IJSCEIT)*, 7(1).
- [10] Dr.V.Vinodhini. (2019). Enhanced parameter less k means and density based clustering algorithm for crime investigation. *International Journal of Scientific Research in Computer Science Applications and Management Studies*.